

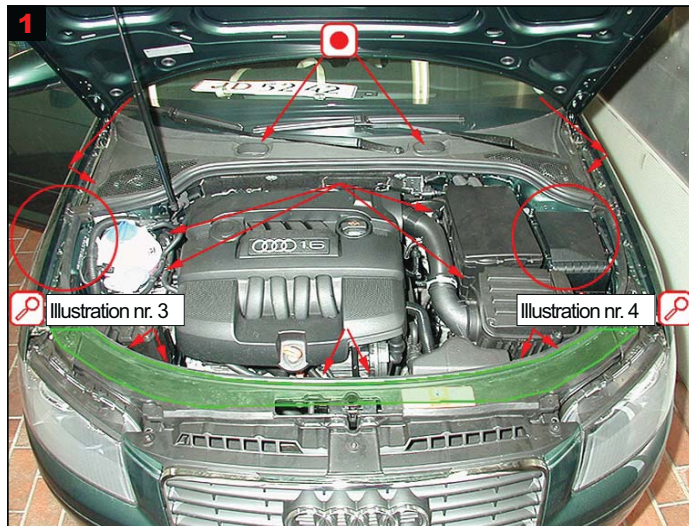

Floor level

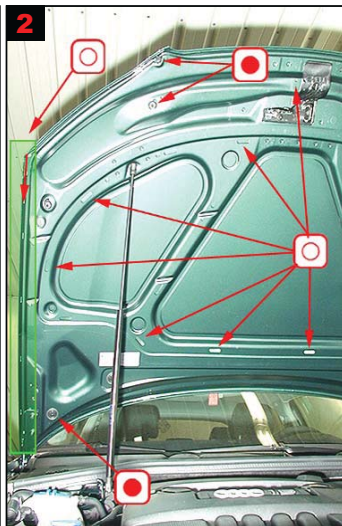

1 Engine compartment:  
Cowl: Treatment via existing plugged holes for washer. Flip plastic plate, treat with caution in underneath.  
Treat on top of longitudinal members, under airfilter box, engine suspension right side, reinforcements on spring strut right side. Treat locking plate. See fig 3 and 4 for correct treatment.



2 Bonnet lid:  
Treat via existing and plugged holes.



7 Front door sectional view:  
Fig: correct drilling. **Note the shallow drilling depth.**

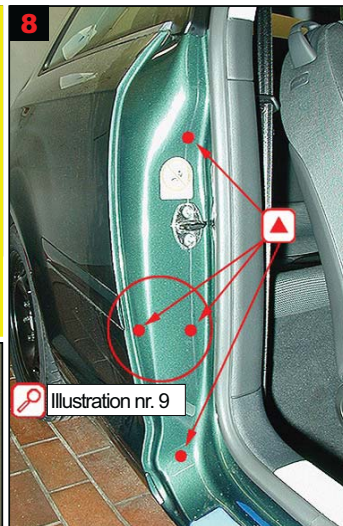

8 B-pillar and rear wing:  
Treat via 4 drilled holes for correct treatment. See fig 9 for drilling at correct level.

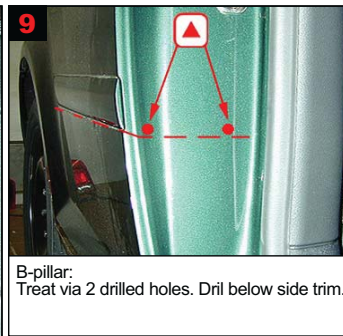

9 B-pillar:  
Treat via 2 drilled holes. Drill below side trim.

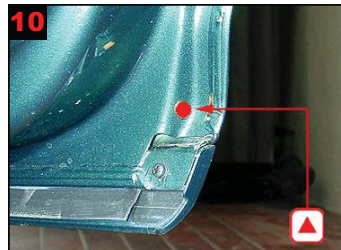

10 Front door sectional view:  
Fig: correct drilling.

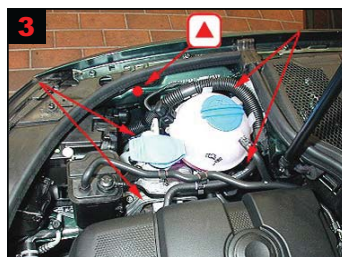

3 Fig: correct drilling of top member.

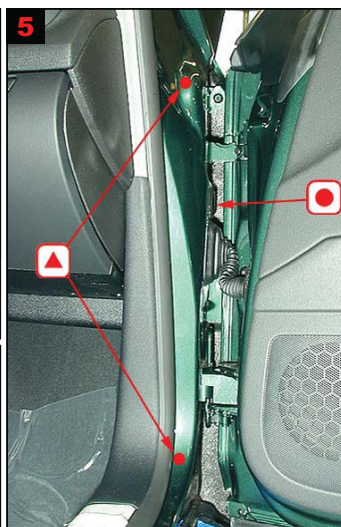

5 A-pillar:  
Treat via 2 drilled holes as well as via existing plugged hole.

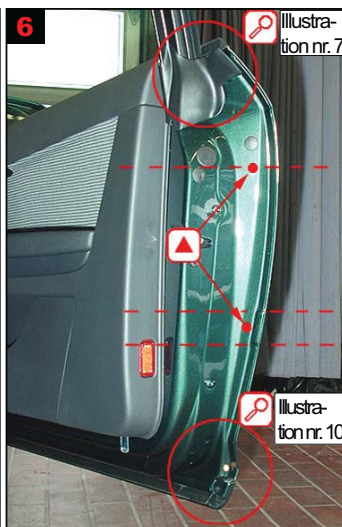

6 Front door:  
Treatment via 4 drilled holes. 2nd. drilling level just above childproof locking device. 3rd drill hole level with side trim. See fig. 7 for correct top drilling. See fig. 10 for drilling at correct level.

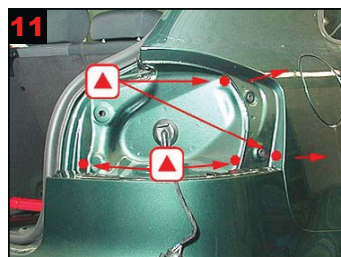

11 Rear wing/rear panel:  
4 drill holes for correct treatment. Rear wing: Treat with lance.

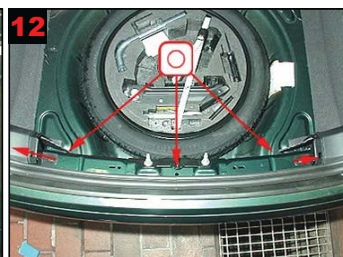

12 Rear panel:  
Remove plastic plate for correct treatment of panel.

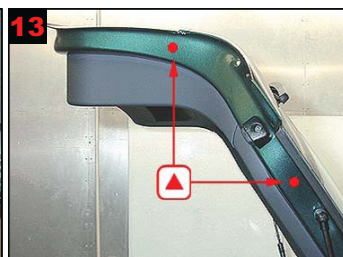

13 Tailgate side:  
Drill 2 holes for correct treatment.



4 Front wing/wheel arch liner:  
Treat via existing holes and gaps.

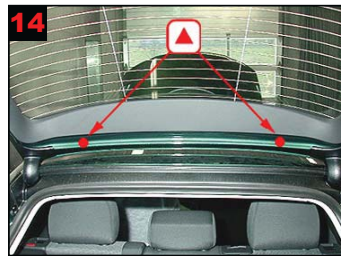

14 Tailgate by roof:  
Treat via 2 drilled holes.



Underside

General view of underside

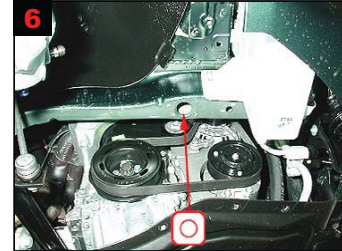
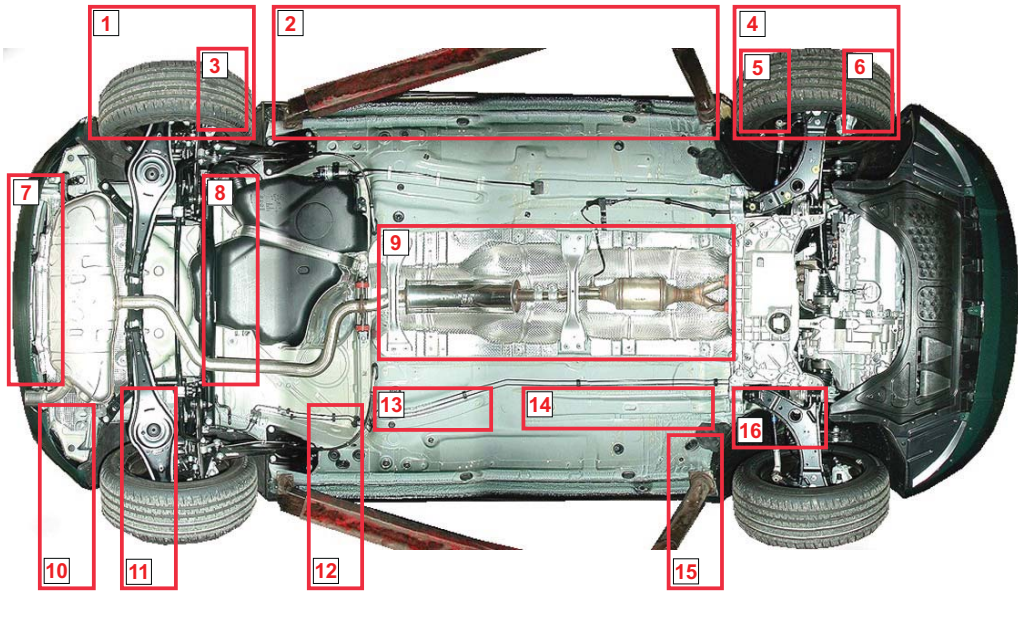

6 Wheel arch front/longitudinal member:  
Treat via existing hole.

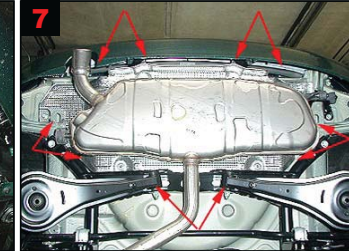

7 Rear panel: Treatment between bumper and rear panel.

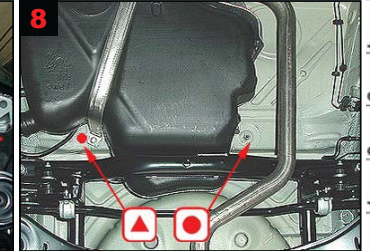

8 Cross member above tank:  
Treat via 1 drilled hole and existing plugged hole.

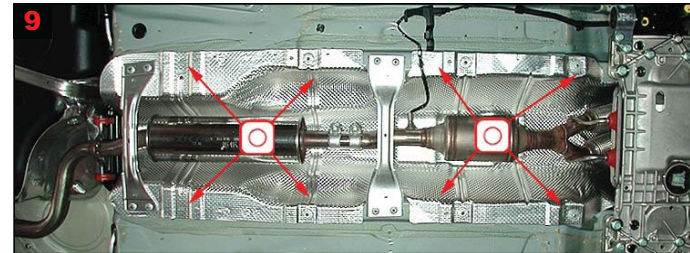

9 Cover plate centre:  
Treatment via existing holes behind cover plate.

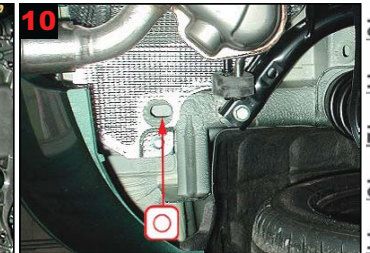

10 Longitudinal member rear:  
Treat via existing holes.

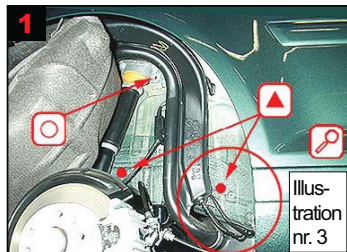

1 Wheel arch rear and panels:  
Flip out wheel arch liner. Treat via 2 drilled holes as well as via existing holes. See fig 3 for correct treatment.

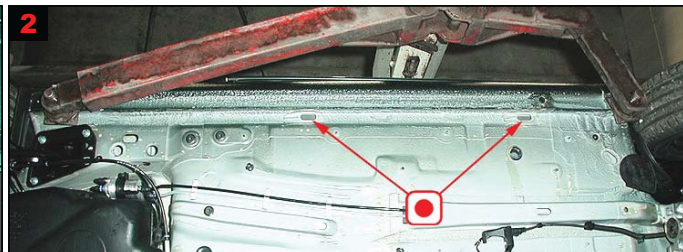

2 Panels:  
Treatment via 2 plugged holes. Note that panel may in places be filled with foam.

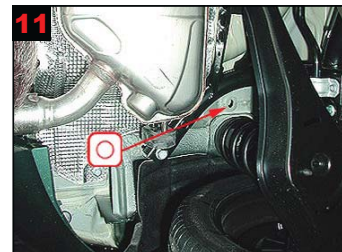

11 Longitudinal members in wheel arch rear:  
Treat via existing holes.

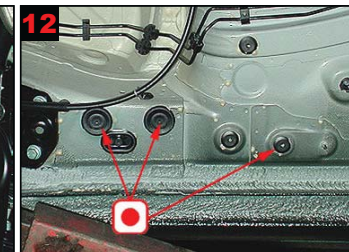

12 Longitudinal member before wheel arch rear:  
Treat via 3 existing plugged holes.

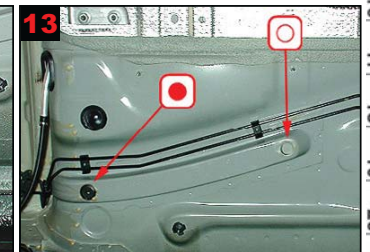

13 Longitudinal members centre rear:  
Treat via existing and plugged holes.

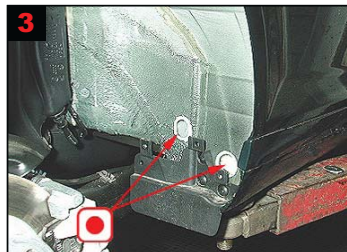

3 Fig. for correct treatment:  
Treatment with long lance.

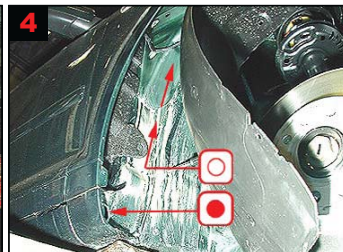

4 Wheel arch front/A-pillar and top member: Flip out wheel arch liner. Treatment of top member and reinforcement via existing holes and gaps. A-pillar: Treat via existing plugged hole.

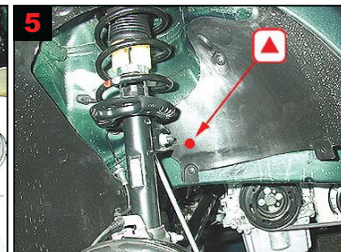

5 Wheel arch front: Drill 1 hole for correct treatment.

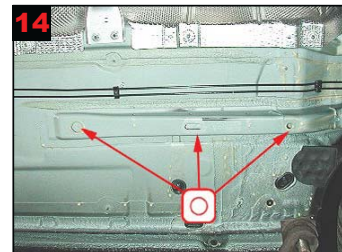

14 Longitudinal members centre:  
Treat via existing holes.



15 Small cross member after front wheel arch:  
Treat via existing plugged hole.

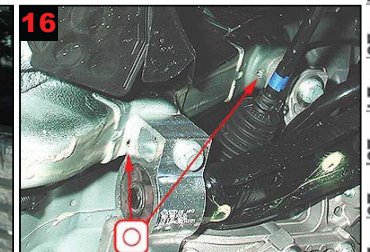

16 Reinforcements front:  
wheel suspension - treat via existing holes.