

1
Engine compartment:
Cowl: Remove rubber strip, flip up plastic plate, treat in underneath.
Treat behind spring struts, along top of longitudinal members, under battery box, around hinges for bonnet lid, cross member above radiator and reinforcement behind radiator grille.

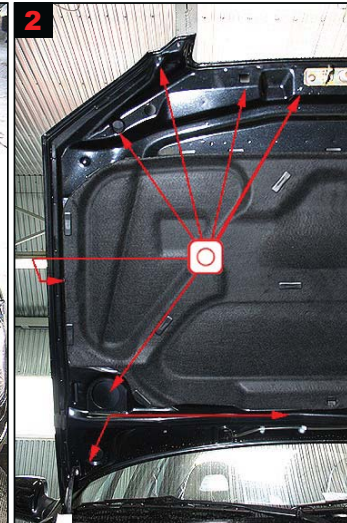

2
Bonnet lid:
Treat via existing holes.



6
Rear door:
Treat via 5 drilled holes.

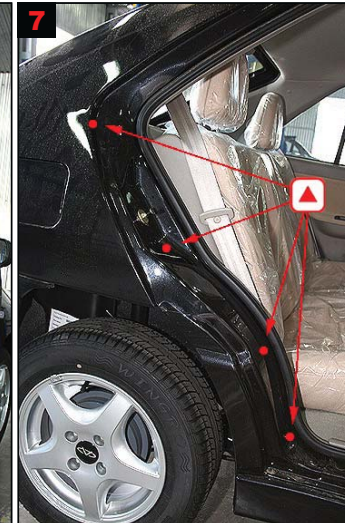

7
C-pillar:
Treatment via 4 drilled holes.



3
A-pillar:
Treat via 3 drilled holes.



4
Front door:
Treatment via 4 drilled holes.
Lower drill hole is drilled with caution.



5
B-pillar:
No treatment because of safety belt and wires.



8
Rear wing:
Treatment from boot.
Flip up lining - treat in all directions.



9
Tailgate:
Treat via existing hole. Drill 5 holes and use 3 existing plugged holes.

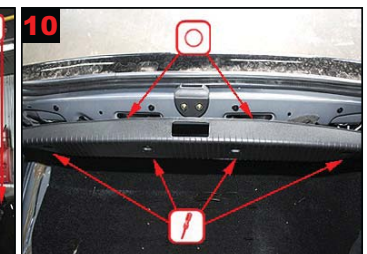

10
Rear panel:
Remove 4 screws, flip up plastic plate.
Treat via existing holes.



General view of underside

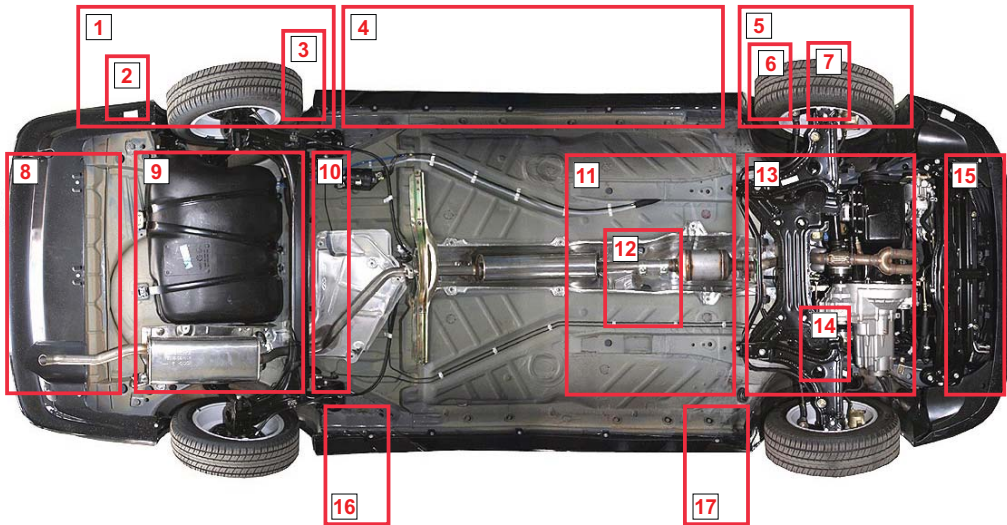

6 Wheel arch front, panel:
Treat via existing plugged hole.

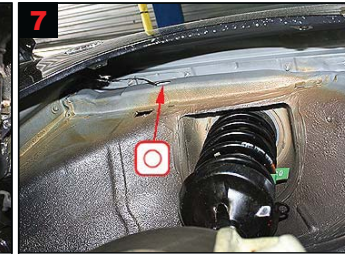

7 Wheel arch front top member:
Treat via existing holes.

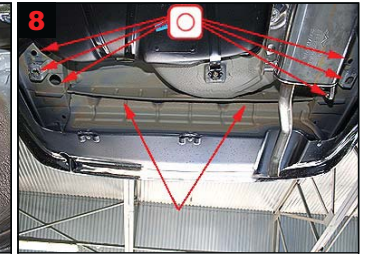

8 Rear panel:
Treat in all directions.
Treat reinforcements via existing holes.



9 Rear axle assembly and reinforcements after tank. Treat via existing holes.

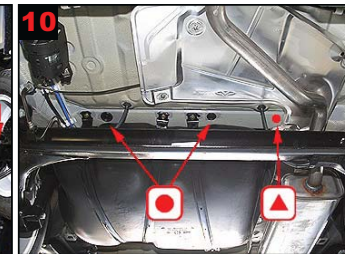

10 Cross member before tank:
Treat via 1 drilled hole and existing plugged holes.

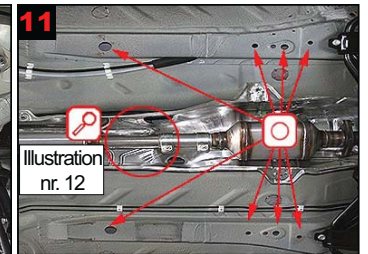

11 Longitudinal members centre:
Treat via existing holes.
Reinforcement above silencer: See fig 12.

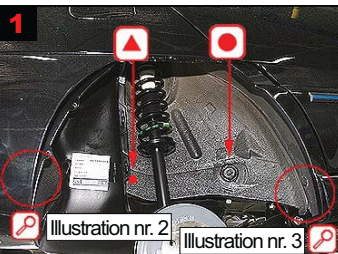

1 Wheel arch rear/longitudinal member:
Treat via 1 drilled hole and existing plugged hole. Rear wing and panel: See fig. 2 and 3.



2 Wheel arch rear/rear wing:
Treat via existing plugged hole.



3 Wheel arch rear/panel:
Treat via existing plugged hole.



12 Reinforcement above silencer:
Treat via existing holes and gaps.

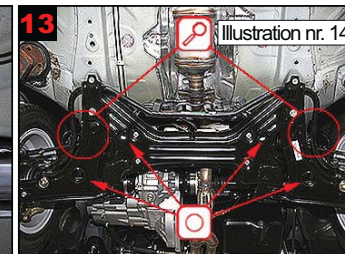

13 Front axle assembly/supports:
Treat via existing holes and gaps.
Reinforcements: Fig 13.

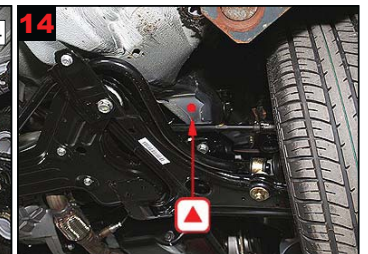

14 Reinforcements for front axle assembly:
Treat via 1 drilled hole each side.

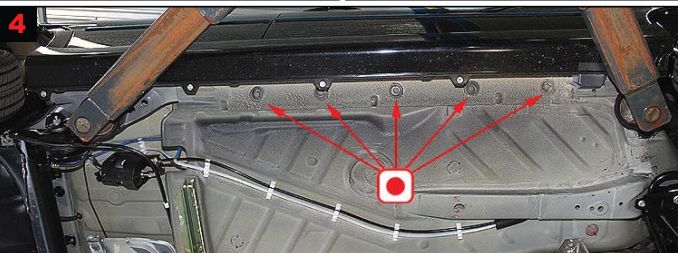

4 Panels:
Treatment via 5 plugged holes.

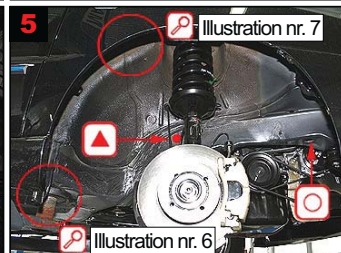

5 Wheel arch front/longitudinal members:
Treat via 1 drilled hole and existing hole.
Panel and top member: Fig 6. and 7.

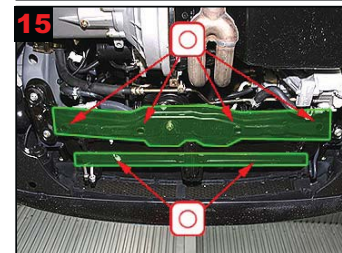

15 Cross member under radiator and member for bumper:
Treat via existing holes.

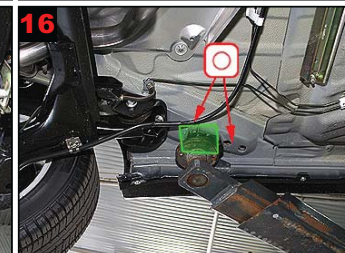

16 Longitudinal member before wheel arch rear and reinforcement:
Treat via existing holes.

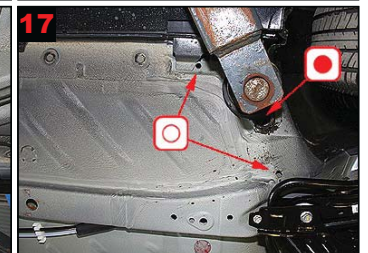

17 Small cross member after front wheel arch:
Treat via existing and 1 plugged hole

1
2
3
4
5
6
7
8
9
10
11
12
13
14
15
16
17
18
19
20
21
22
23
24
25
26
27
28
29