

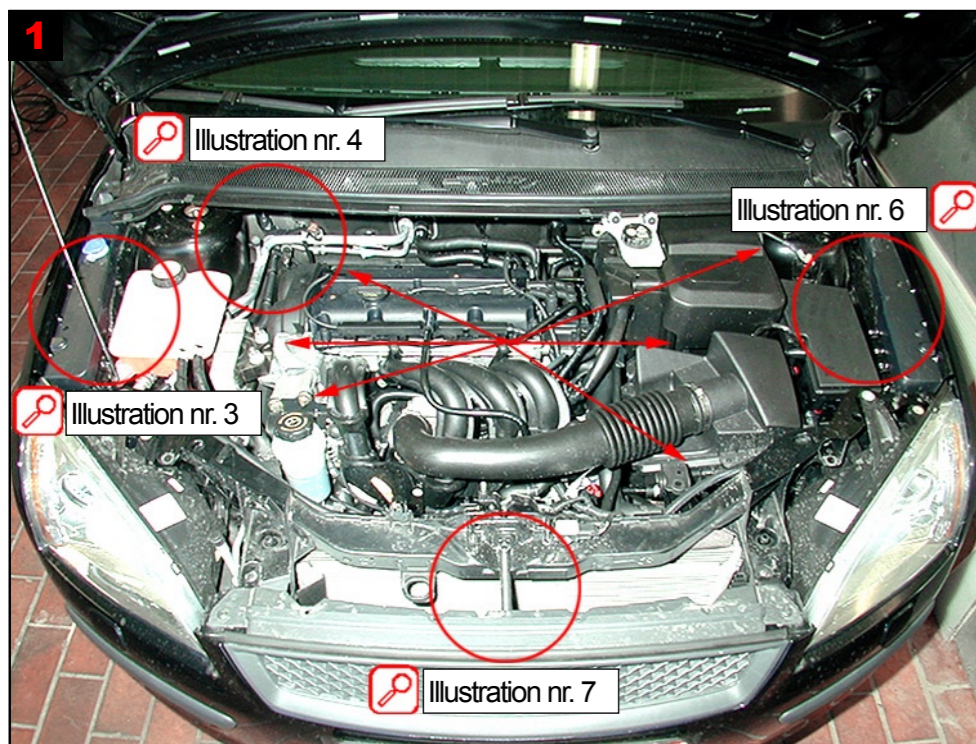

Floor level

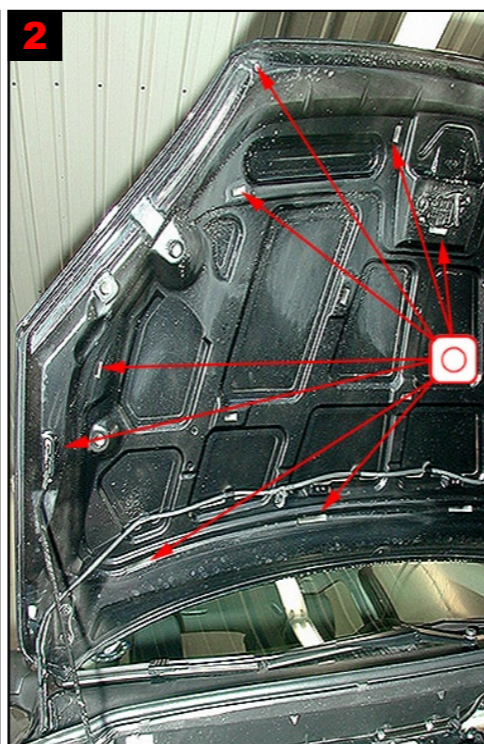

1
Engine compartment:
Treatment behind spring struts, on top of longitudinal members, under fluid reservoir, under air filter box and fuse box, treat up under locking plate and side fittings for radiator. See fig 3, 4, 6 and 7.



2
Bonnet lid:
Treat via existing holes and gaps.

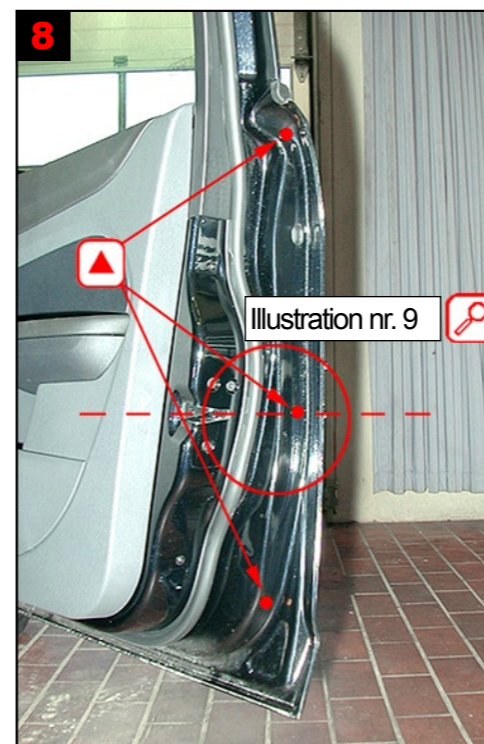

8
Front door:
3 drill holes for correct treatment. See fig 9 for drilling at correct level.

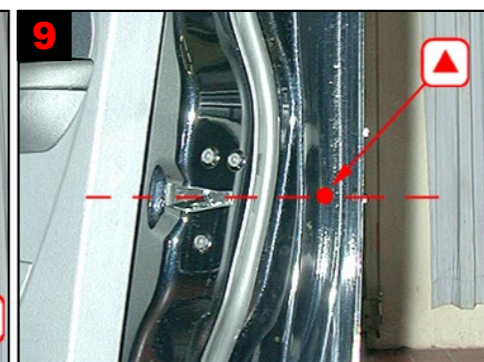

9
Front door sectional view:
Fig: drilling at correct level.

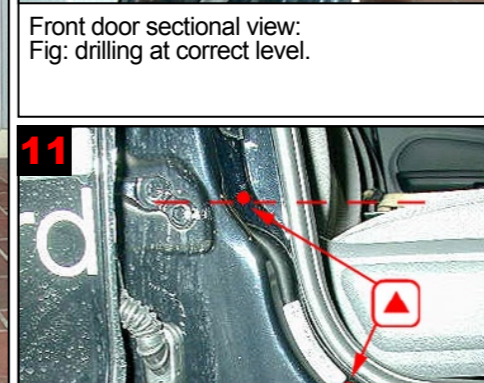

11
B-pillar:
Drill 2 holes for correct treatment.

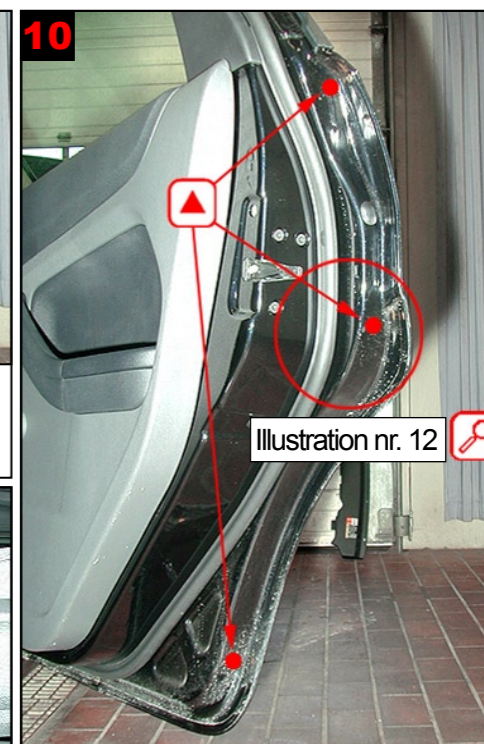

10
Rear door:
3 drill holes for correct treatment. See fig. 12 for correct drilling level.



3
Engine compartment sectional view, right side:
Flip plastic plate - treat right across. Treatment around hinges for bonnet lid.



4
Cross member behind engine:
Treat via existing holes.

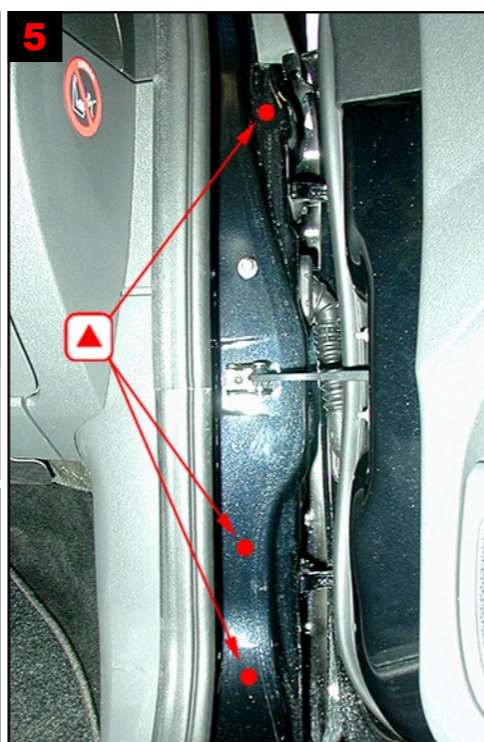

5
A-pillar:
3 drill holes for correct treatment.

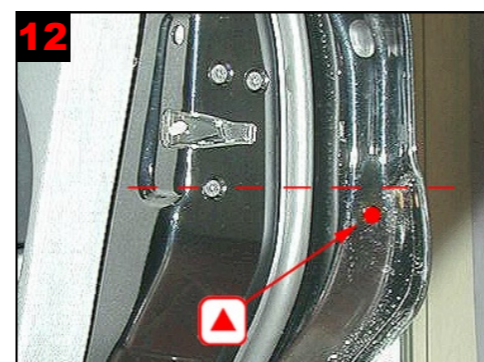

12
Rear door sectional view:
Centre drill hole is drilled app. 2 cm below level for screws for door lock.



13
C-pillar/rear wing:
Drill 2 holes for treatment with lance.

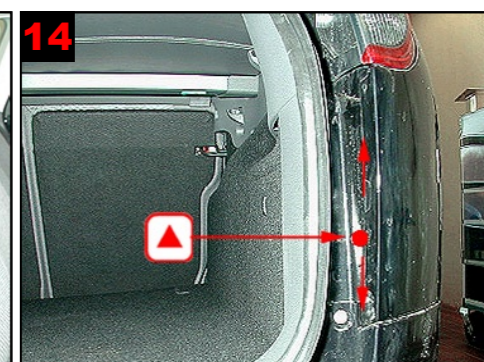

14
Rear wing:
Treatment via 1 drill hole below tail light.

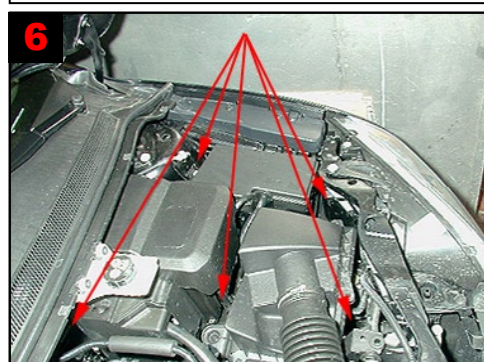

6
Engine compartment - sectional view:
Fig. for correct treatment.

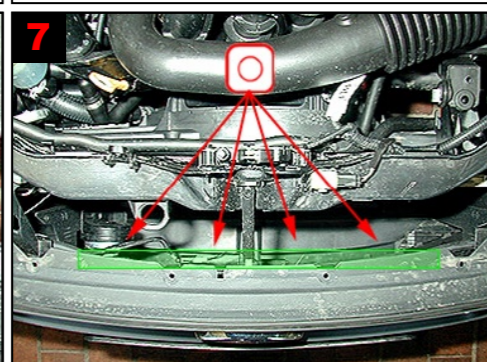

7
Cross member behind bumper:
Treat via existing holes.

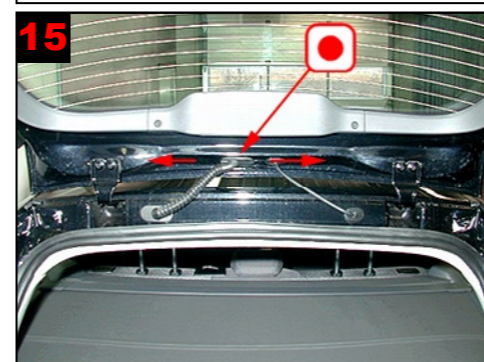

15
Tailgate by roof:
Treat via grommet.

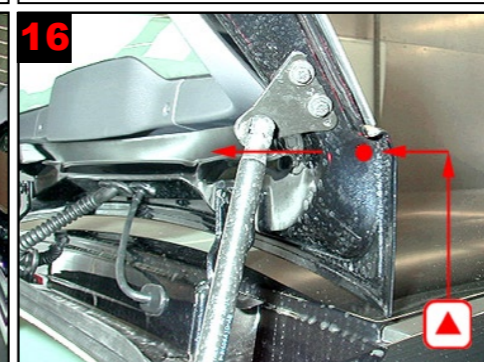

16
Tailgate side by roof:
Drill 1 hole for correct treatment. (caution when advancing lance).



17
Tailgate side:
Drill 2 holes for correct treatment. (caution when advancing lance).

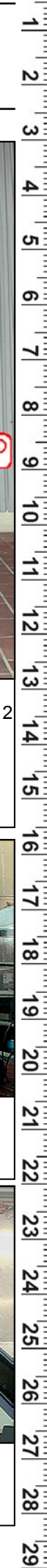



Underside

General view of underside

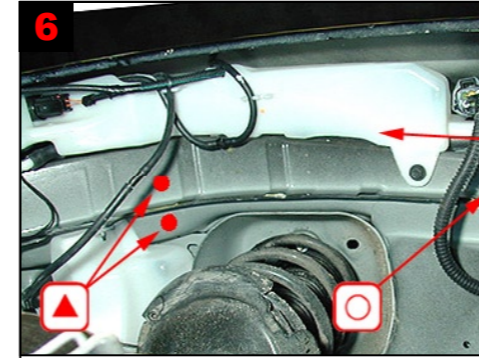
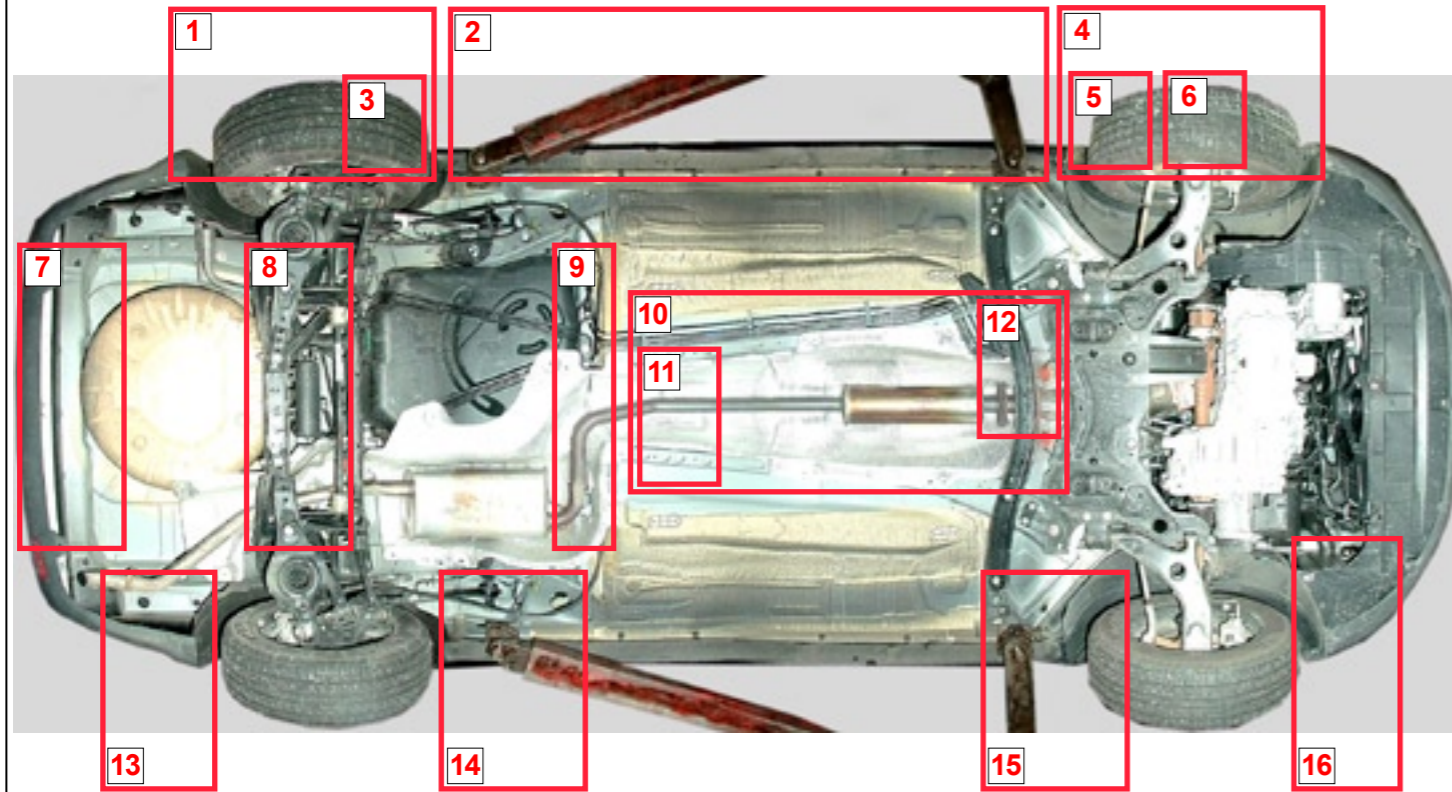

6
Wheel arch front top member:
Drill 2 holes for correct treatment. Treat via existing holes and gaps.

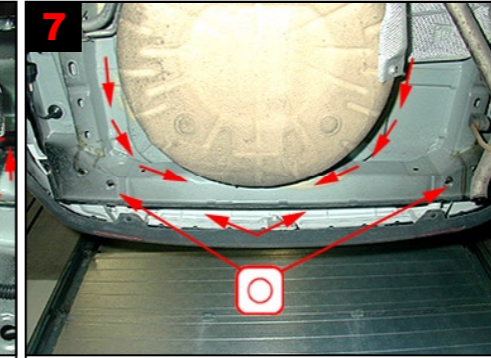

7
Rear panel:
Treat via existing holes and gaps.

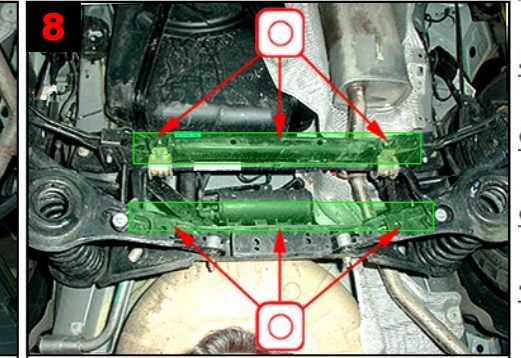

8
Cross member above rear axle assembly.
Treat via existing holes.

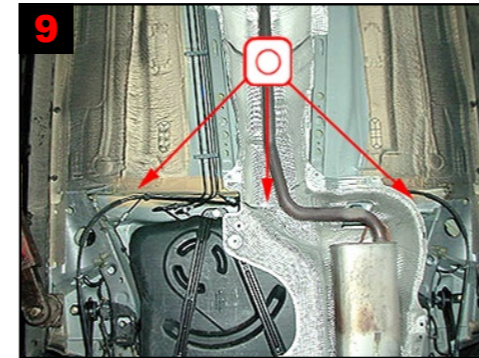

9
Cross member before tank:
Treat via existing holes.

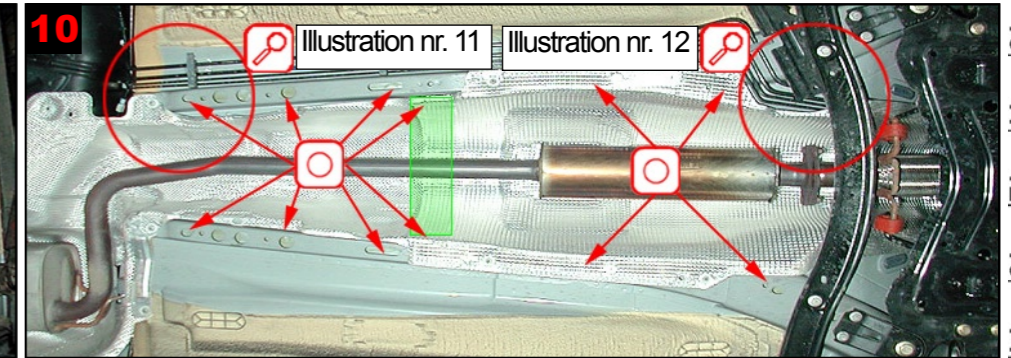

10
Longitudinal members centre and auxiliary members:
Treat via existing holes and gaps. See fig 11 and 12.

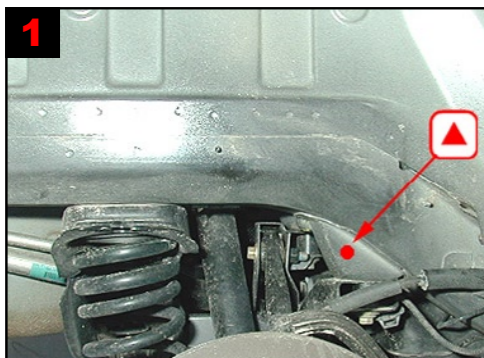

1
Longitudinal member in wheel arch rear:
Drill 1 hole in reinforcement for wheel suspension.

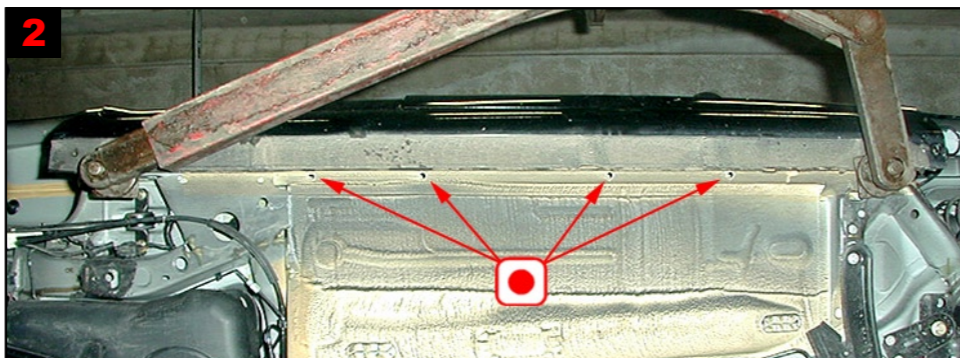

2
Panel:
Treat via 4 existing plugged holes.

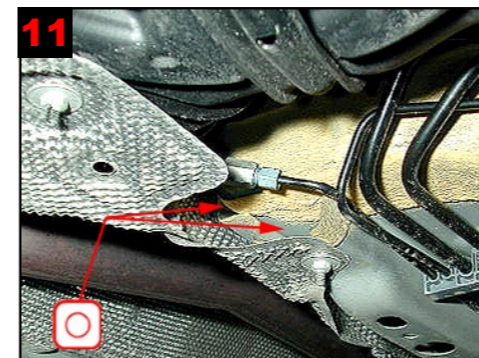

11
Fig. for correct treatment.

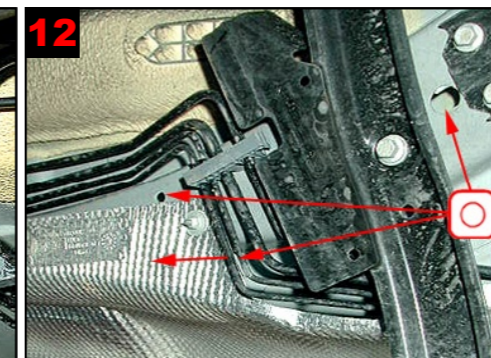

12
Fig. for correct treatment.

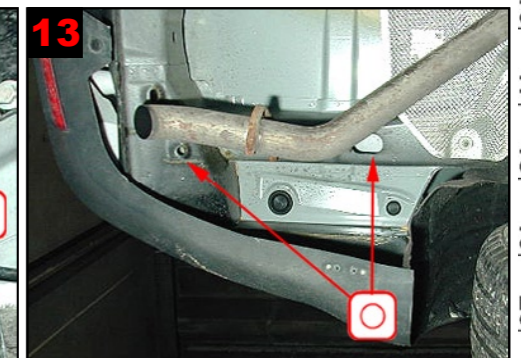

13
Longitudinal member rear:
Treat via existing holes.

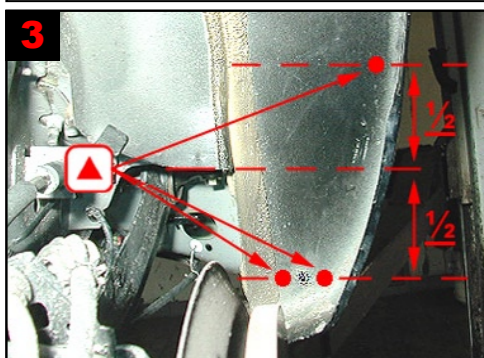

3
Wheel arch rear/panel: 2 drill holes for correct treatment of inner and outer panel (treat with lance). Drill 1 hole for part treatment of C-pillar and rear wing.

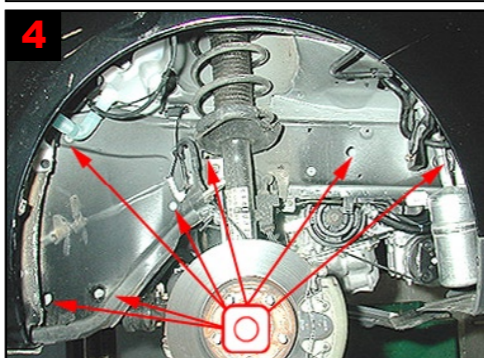

4
Longitudinal members in wheel arch front:
Treat via existing holes.

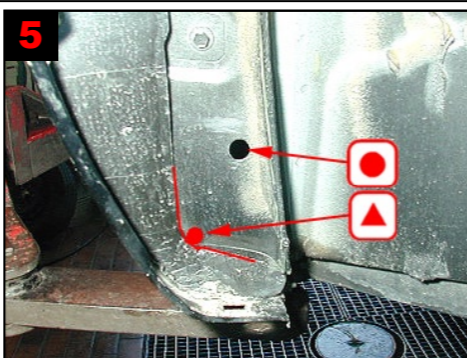

5
Wheel arch front/panel:
Treat via 1 drilled hole and existing plugged hole.

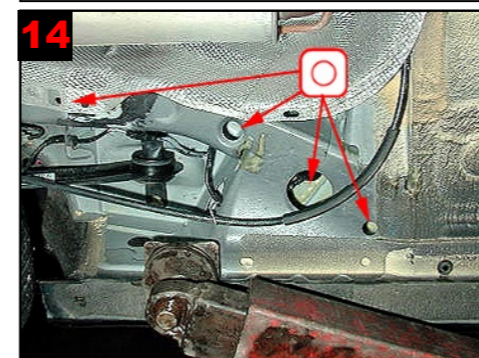

14
Longitudinal member before wheel arch rear:
Treat via existing holes.

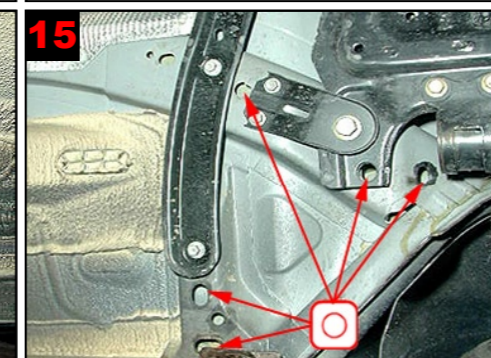

15
Small cross member after front wheel arch:
Treat via existing holes.

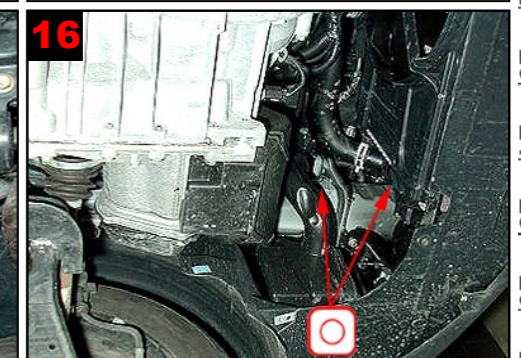

16
Longitudinal member front:
Treat via existing holes.

1
2
3
4
5
6
7
8
9
10
11
12
13
14
15
16
17
18
19
20
21
22
23
24
25
26
27
28
29